

- **WATERPROOF SLIP RING DESIGN**
- **DURABLE CONSTRUCTION**
- **BALL BEARING SLIP RING**
- **PORTABLE SUITCASE DESIGN WITH WHEELS**

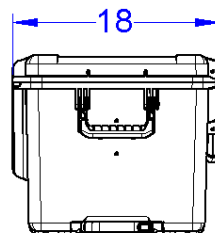
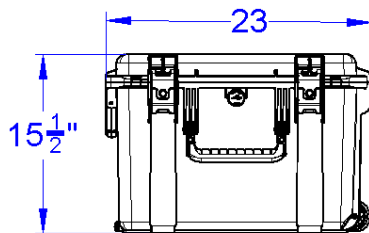
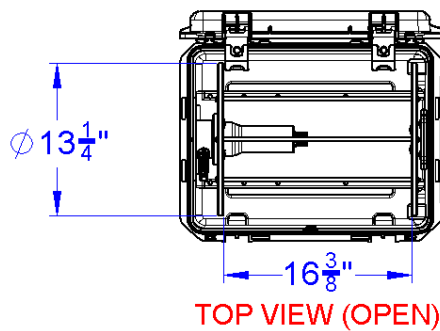

**OVERALL SPECIFICATIONS:**

External Width.....	18.0 in. (45.8 cm)
External Length.....	23.0 in. (58.6 cm)
External Height (Closed).....	15.5 in. (39.5 cm)
Weight (without cable).....	~30 lbs. (13.6 kg)

**DIVE CABLE (C-2300C):**

Cable Diameter.....	0.38 in. (9.7 mm)
Total Length Capacity.....	~500 ft. (~160 m)
Cable Weight.....	~38 lbs. (17.2 kg)
Total Weight.....	~68 lbs. (30.8 kg)

**REEL DIMENSIONS:**

Traverse Length.....	16.38 in. (41.6 cm)
Fill Diameter.....	13.25 in. (33.65 cm)
Barrel Diameter.....	8.5 in. (21.6 cm)

**OPTIONS:**

1. Customer Specified Connector